

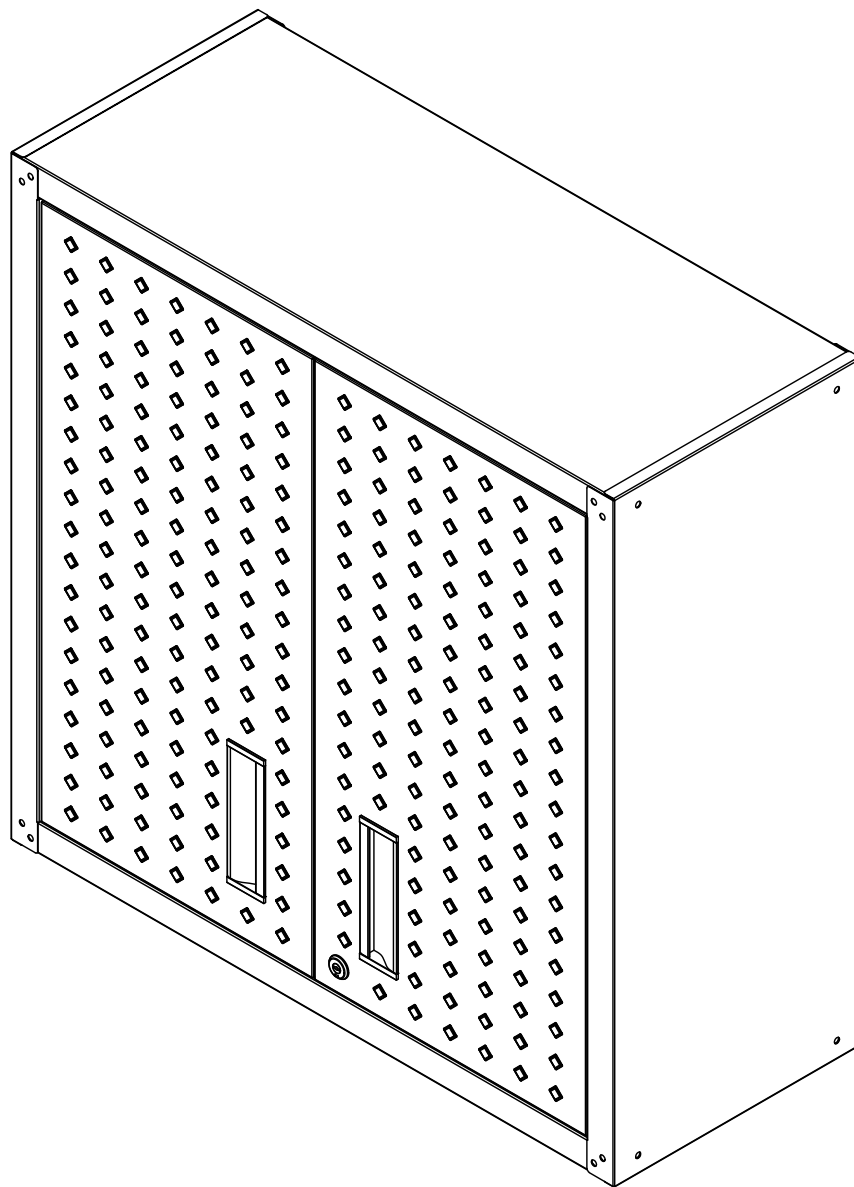

MANHATTAN COMFORT

Model: 5GMC





STOP!

Before beginning the assembly process, ensure all boxes and parts have been delivered.

FOR BEST RESULTS:

- Do not throw away packaging materials until assembly is complete.
- Assemble item on a soft surface, such as cardboard or carpet, to protect finish.
- Proper assembly requires two people.

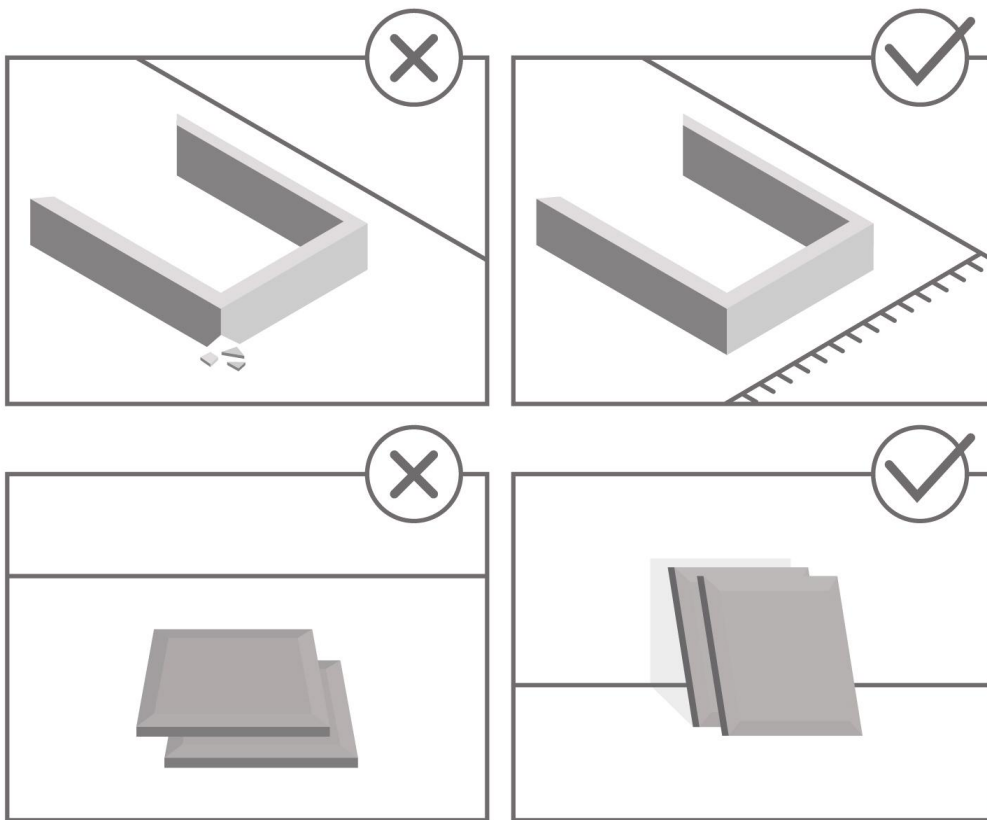

TOOLS REQUIRED

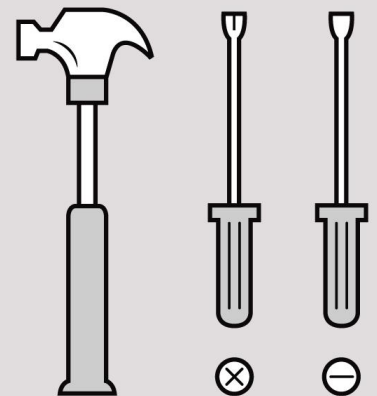

View our assembly video online:
WWW.MANHATTANCOMFORT.COM



Stuck? Question? We are here to help.
tel: 908-888-0818
e-mail: help@manhattancomfort.com

Support Site



Fortress Floating Garage Cabinet

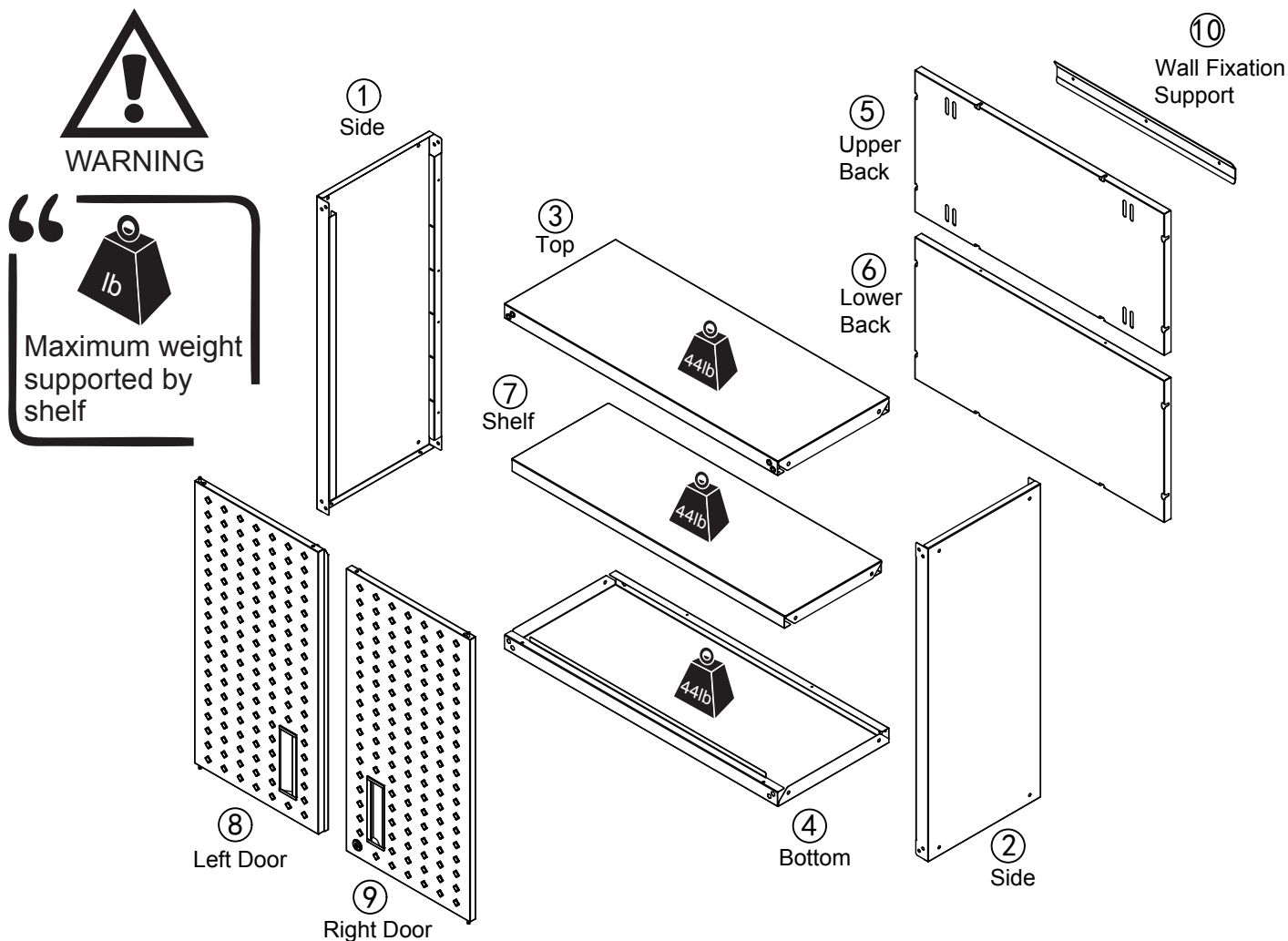

Hardware list

A

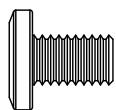

M6×10mm
16 ×

B

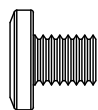

M6×8mm
8 ×

C



M6
8 ×

D

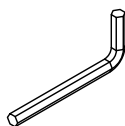

4mm
1 ×

E

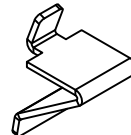

4 ×

F

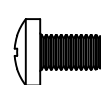

M4×8mm
14 ×

G



2 ×

H



4×40mm
3 ×

J

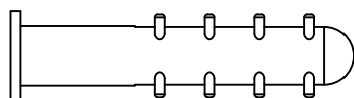

Ø8×40mm
3 ×

K

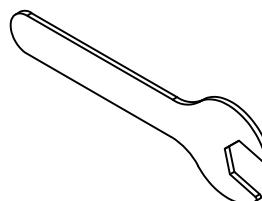

1 ×

L

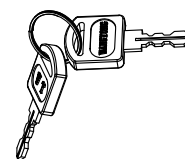

1 ×

M



4 ×

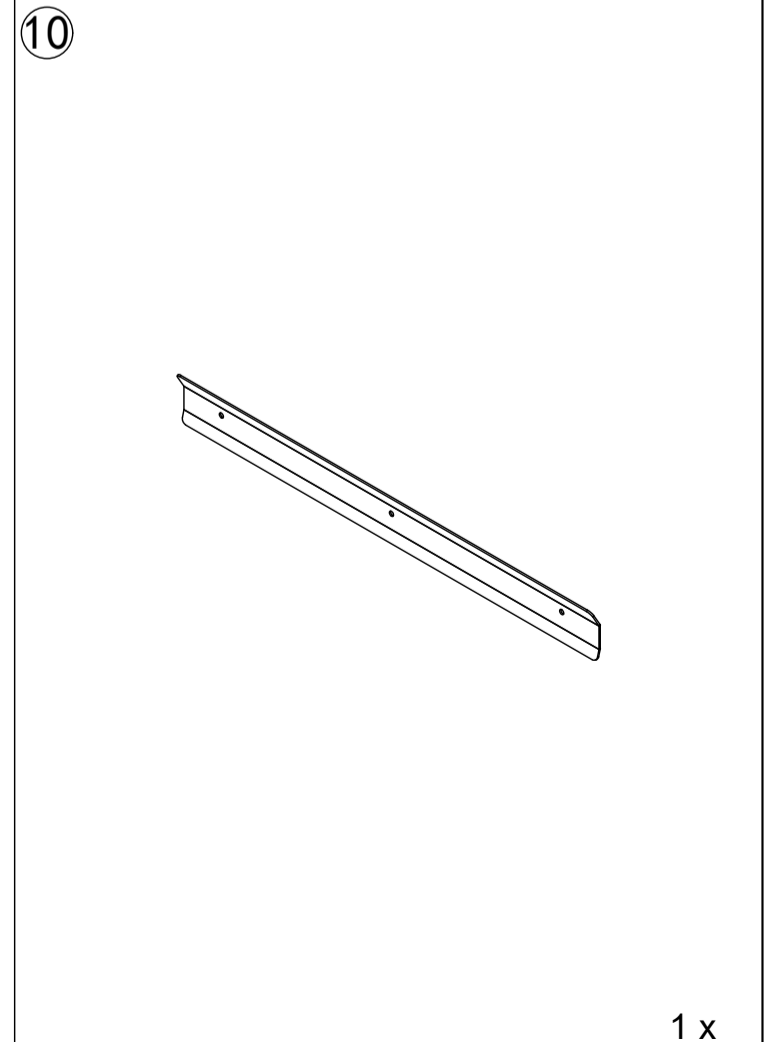
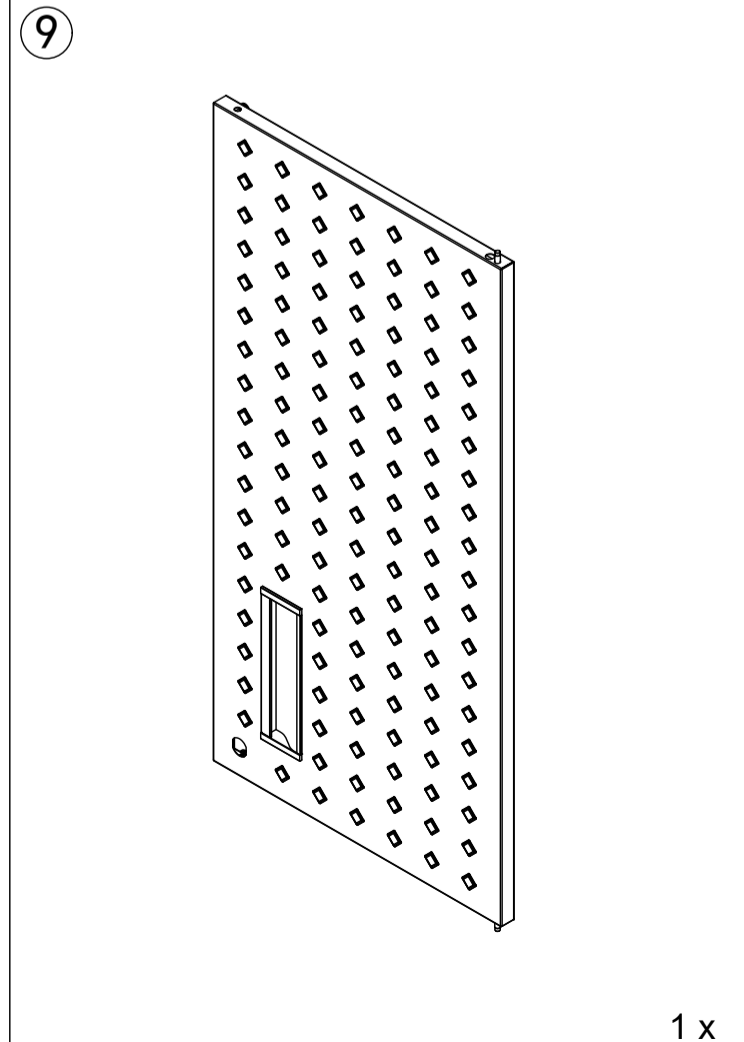
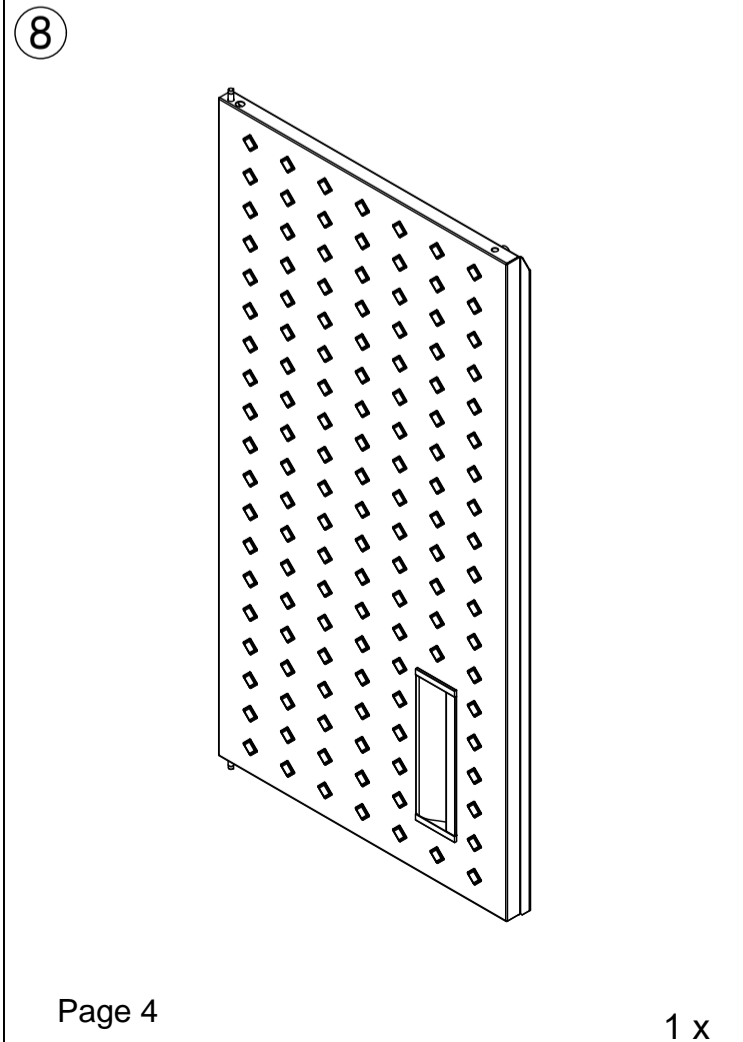
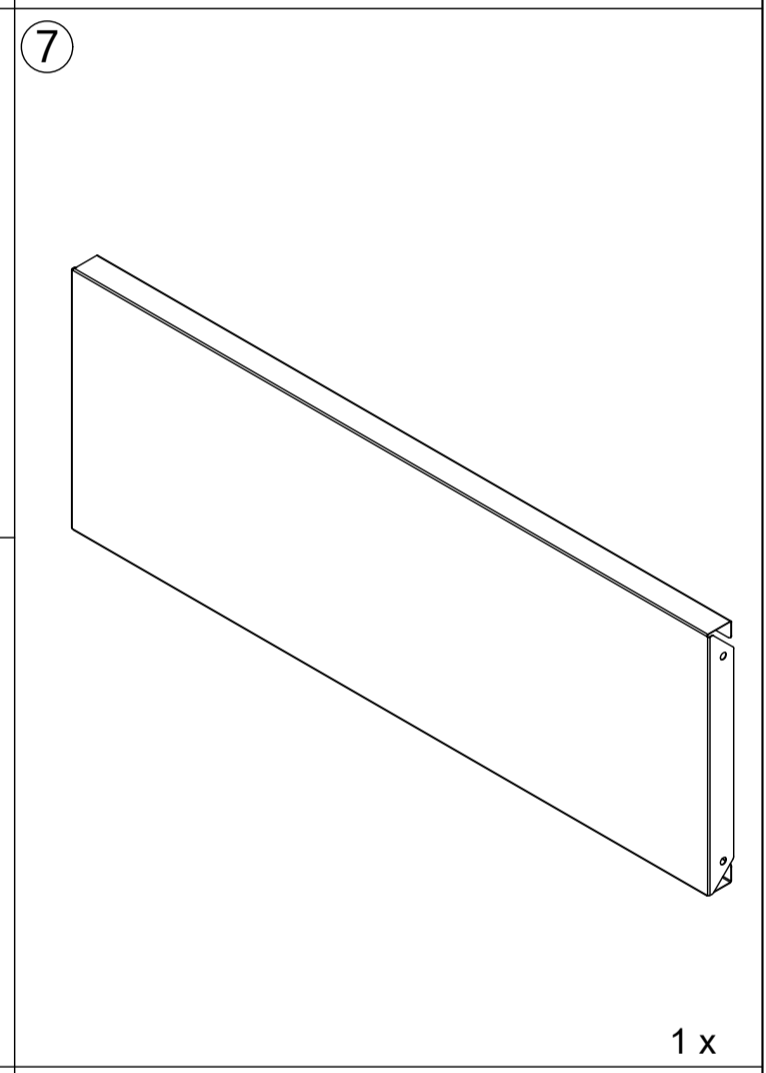
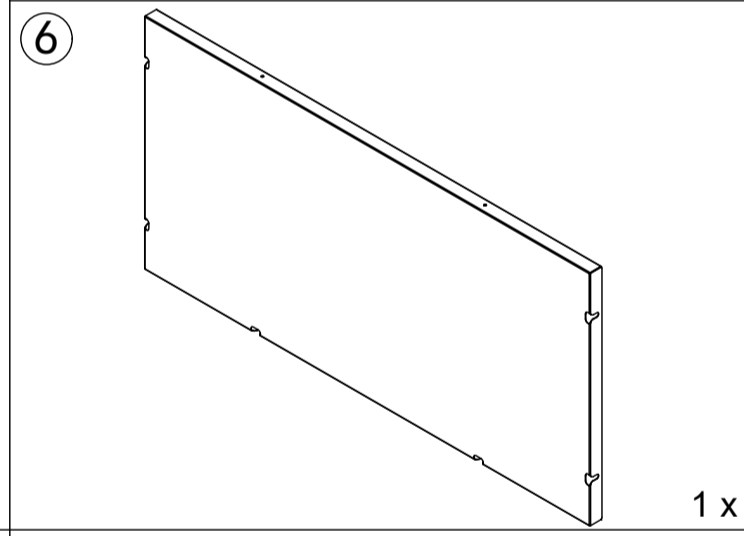
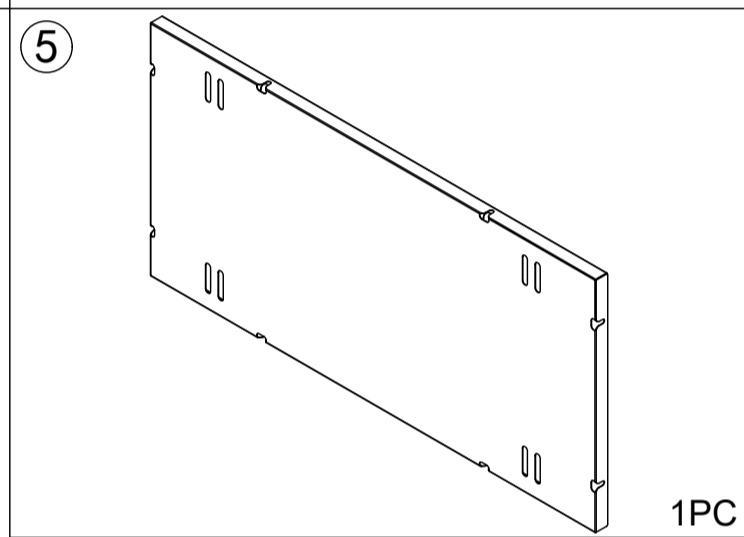
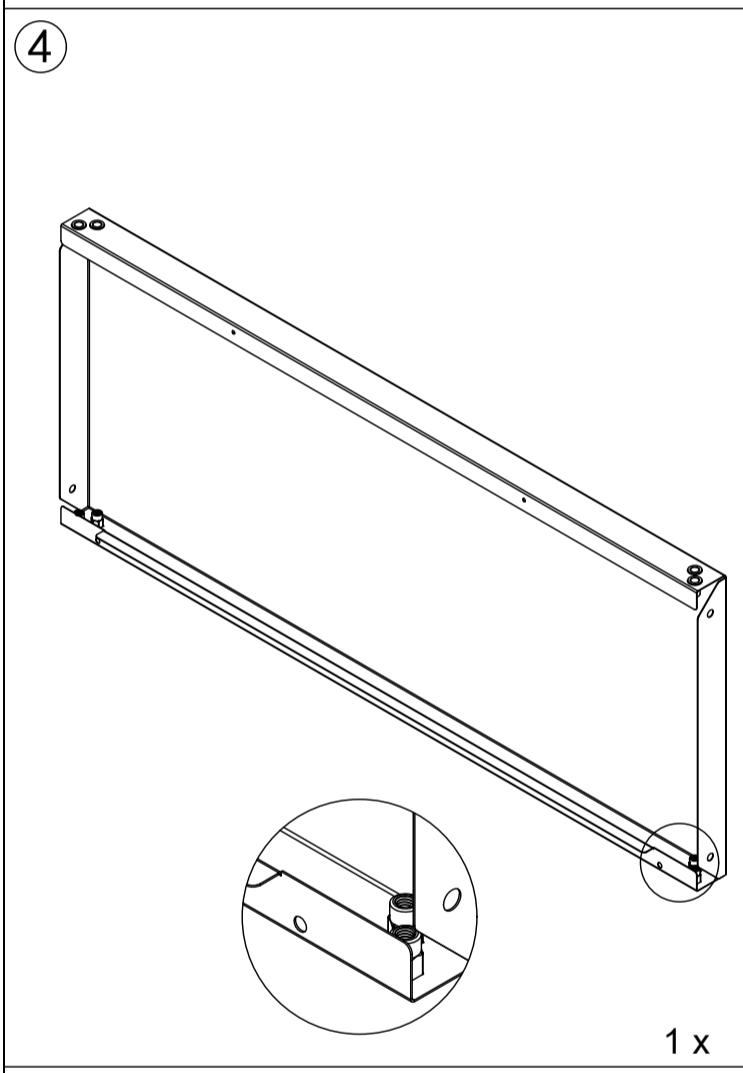
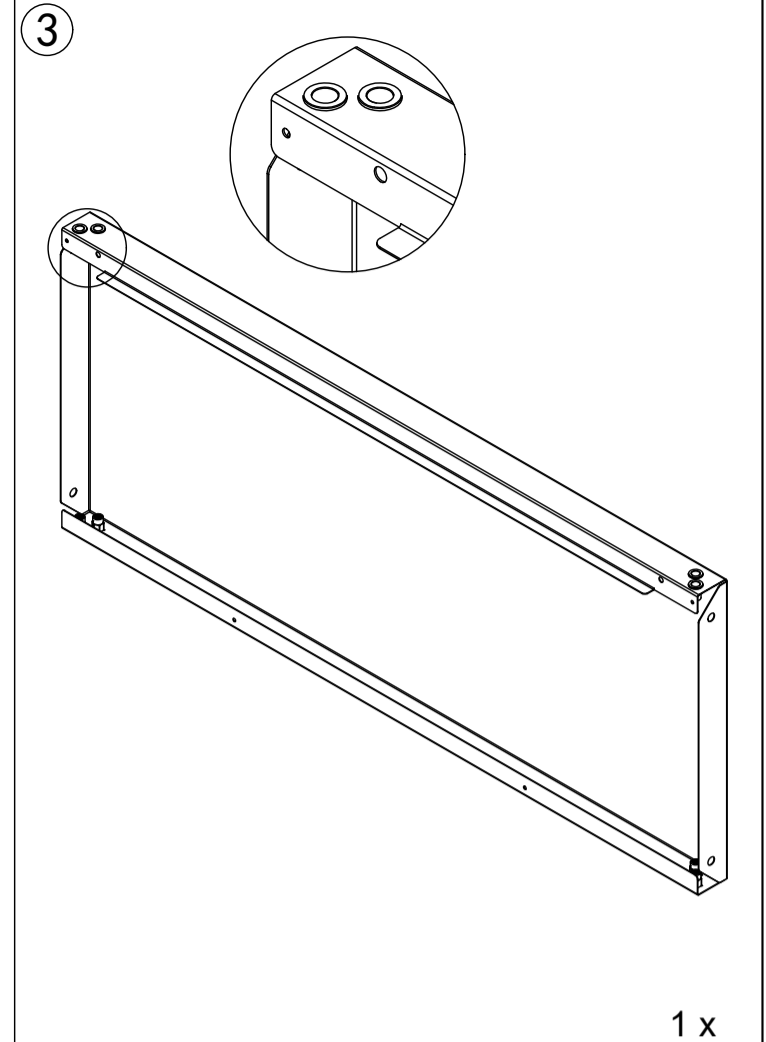
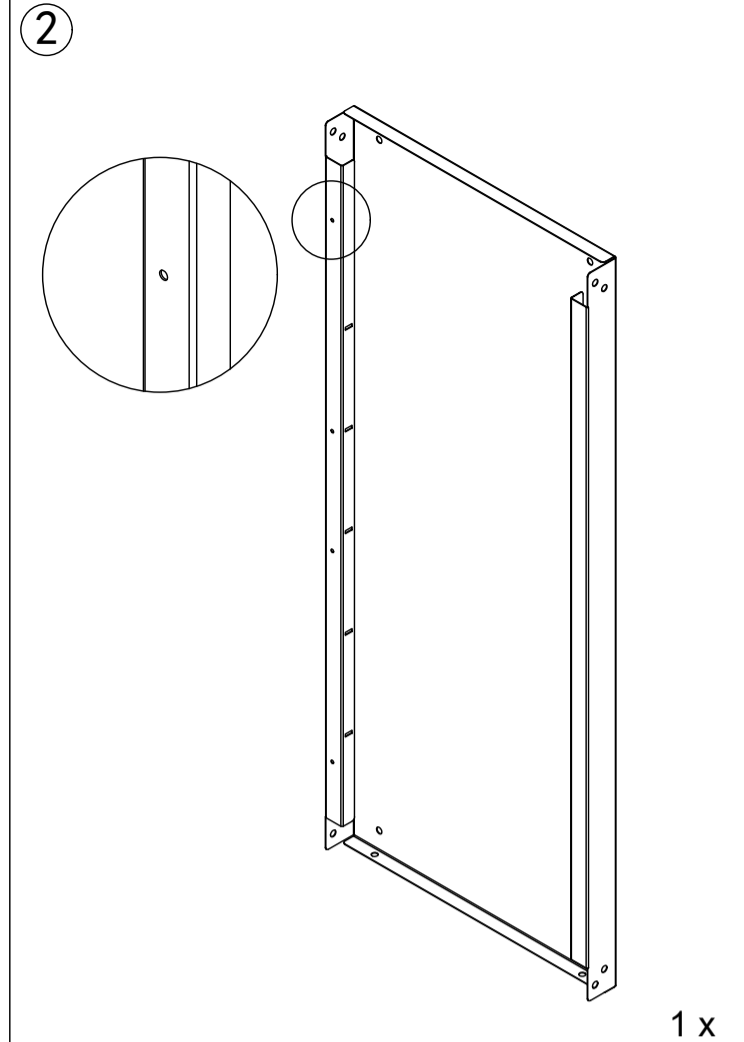
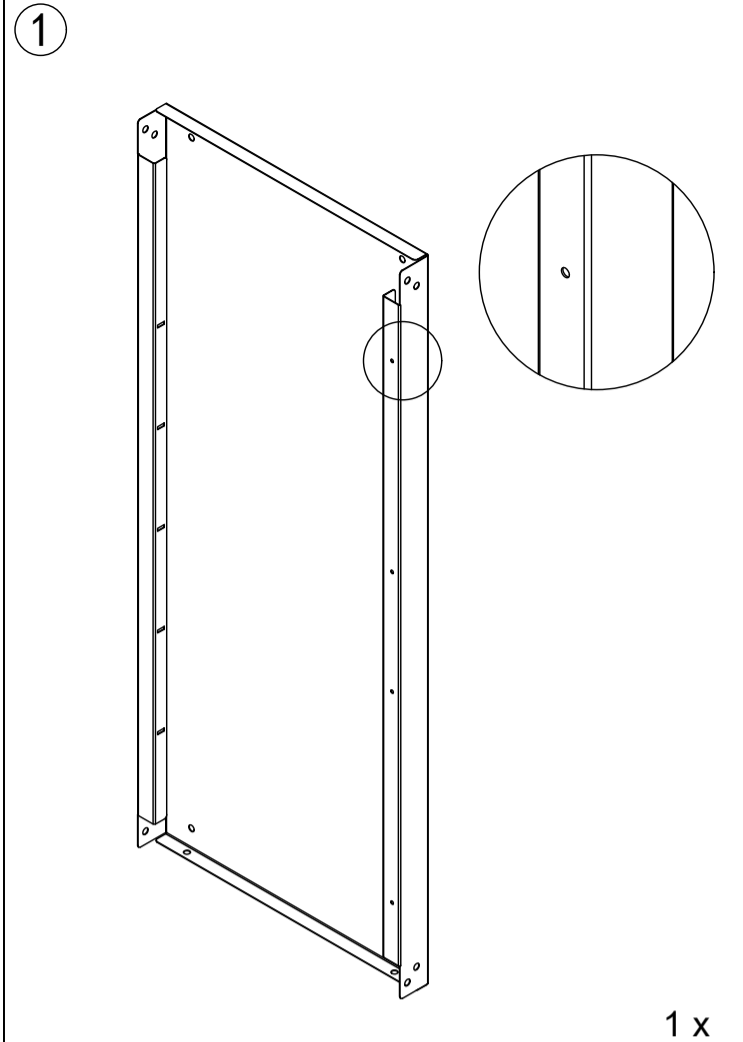

STEP 1

- 1 - Fit part ③ into part ②
- 2 - Fit both parts in the frontal side, with A and D

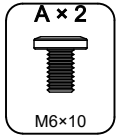

“ Check that part ② is in the correct "up" direction as the arrow showing. ”

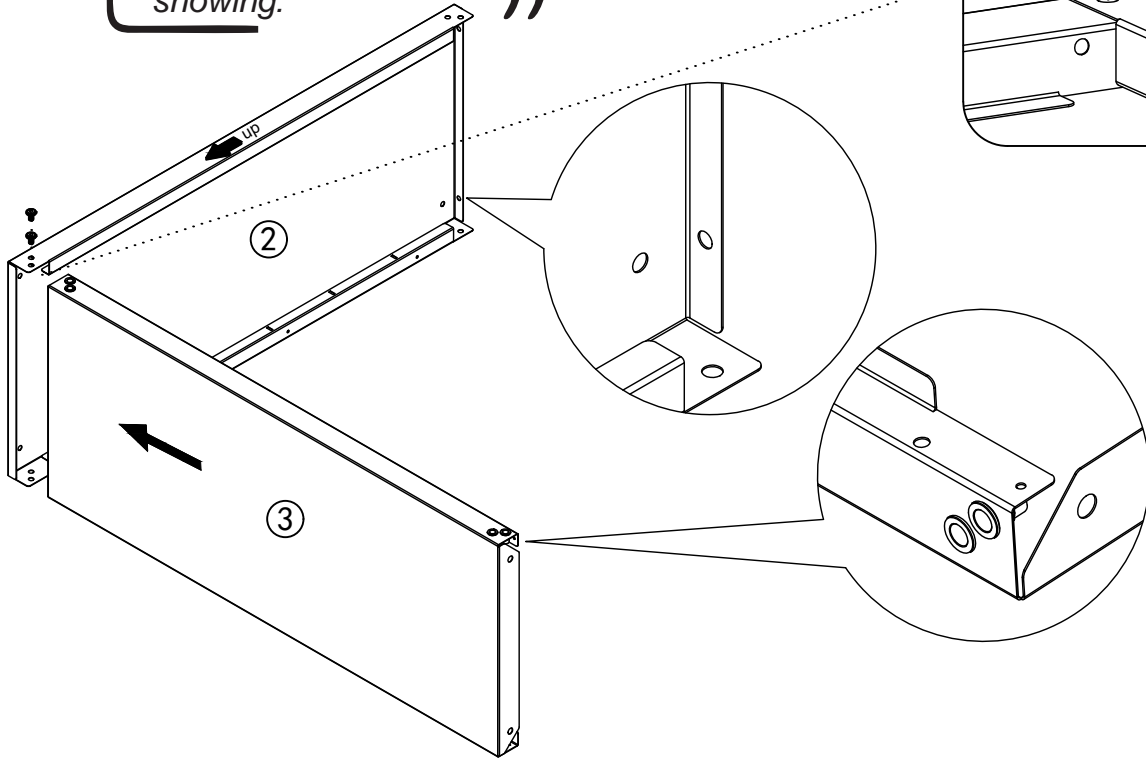
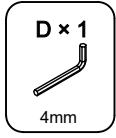

STEP 2

- 1 - Fit part ④ into part ②
- 2 - Fit both parts in the frontal side, with A and D

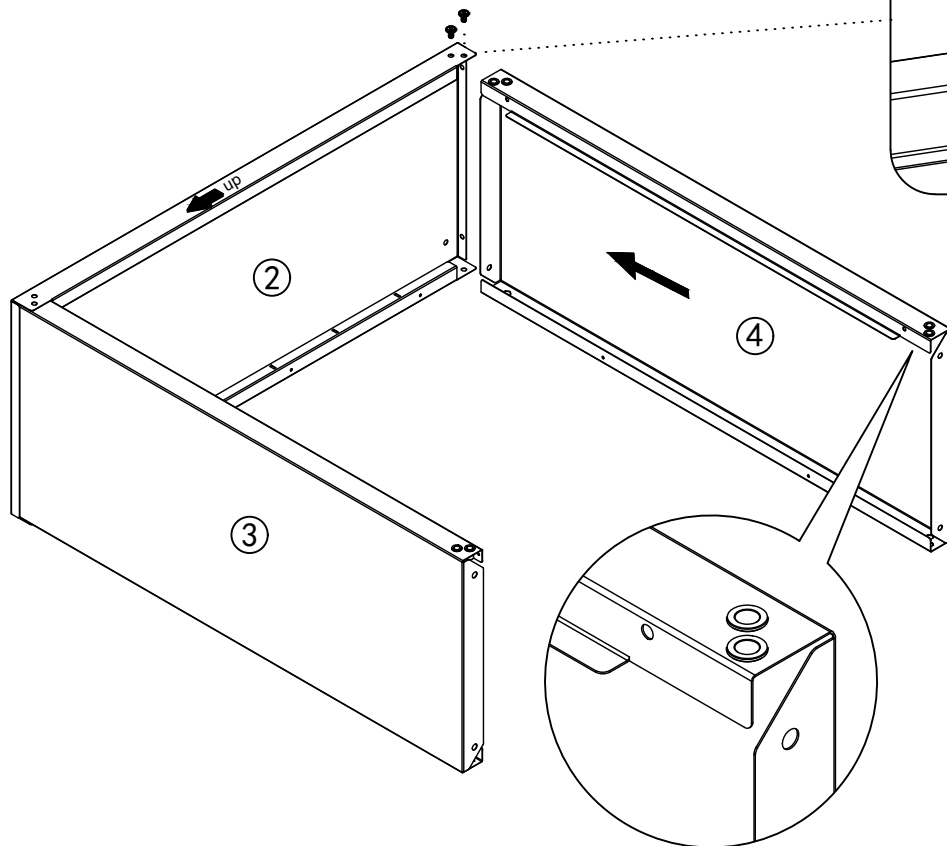
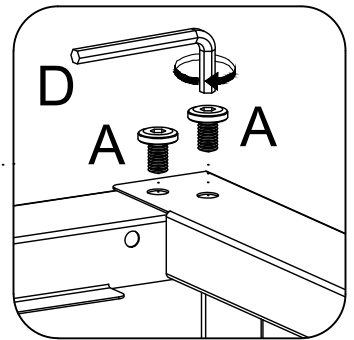
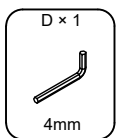
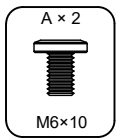

STEP 3

- 1 - Fit part ③ & part ④ into part ①
- 2 - Fit part ① to part ③ & part ④ at the frontal side, with A and D

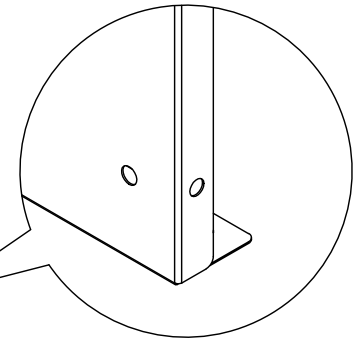
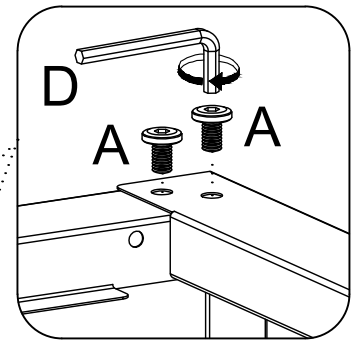
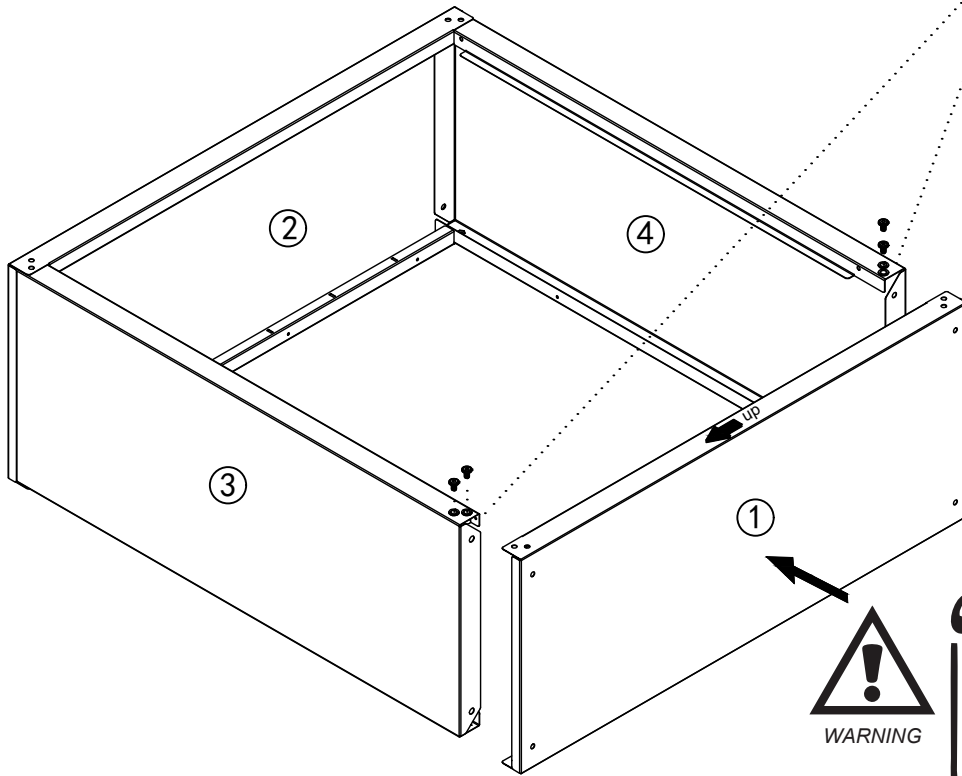
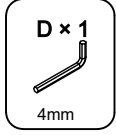
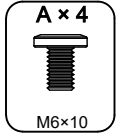

“ Check that part ① is in the correct "up" direction as the arrow showing.

STEP 4

- 1- Turn the cupboard with the back side upwards
- 2- Fit part ① & part ② to part ③ & part ④ at the frontal side, with A and D

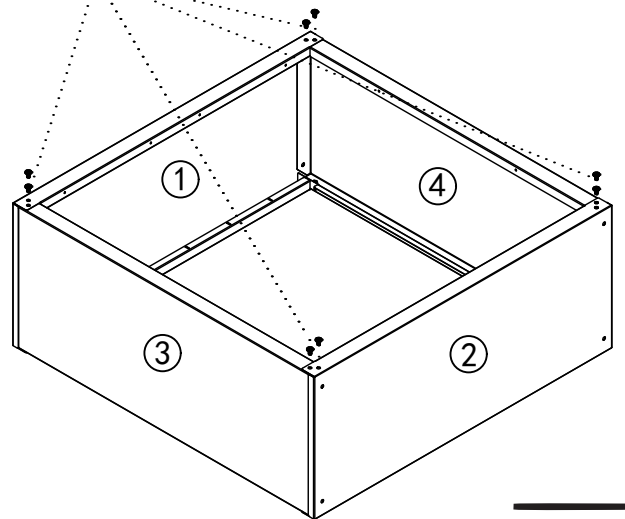
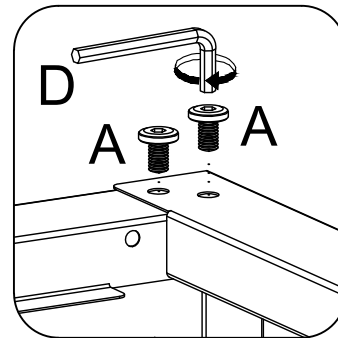
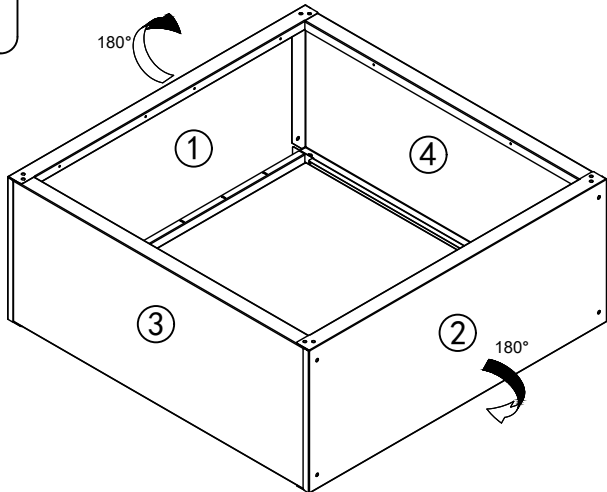
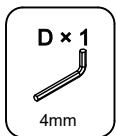
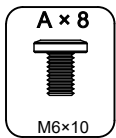

“ Check that all parts are correctly supported to ensure product alignment.

STEP 5

1 - Fit part ① & part ② to part ③ & part ④, at the left and right side with B, C, D and K

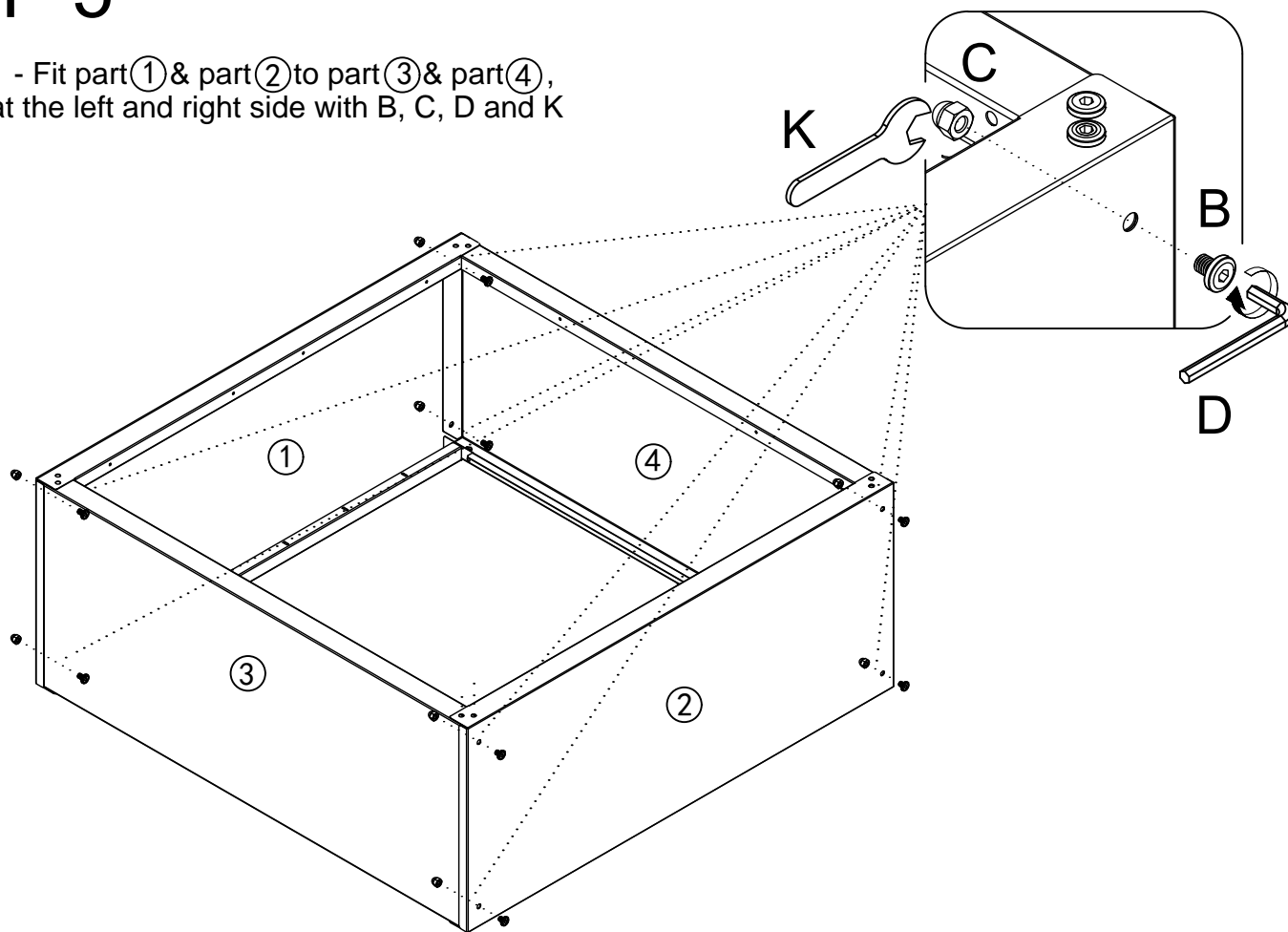
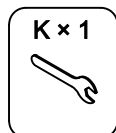
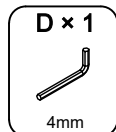
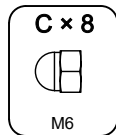
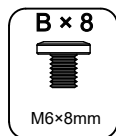

STEP 6

- 1 - Fit part ⑥ into part ①, part ② and part ④
- 2 - Check that all fits are supported over the bolts
- 3 - After fitting the parts, screw the bolts until locked

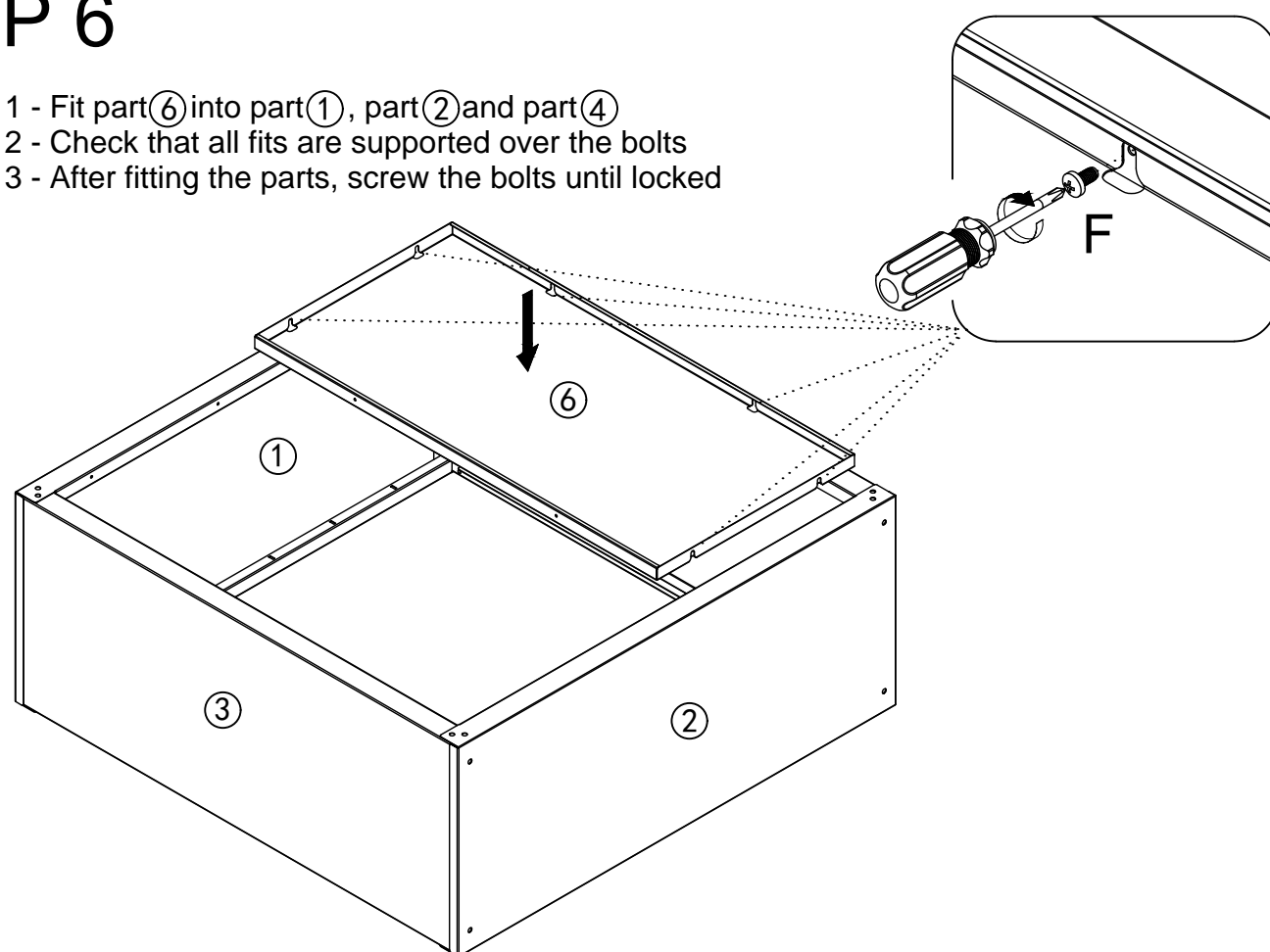
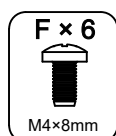

STEP 7

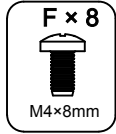

- 1 - Fit part ⑤ into part ①, part ②, part ③ and part ⑥
- 2 - Check that all fits are supported over the bolts
- 3 - After fitting the parts, screw the bolts until locked

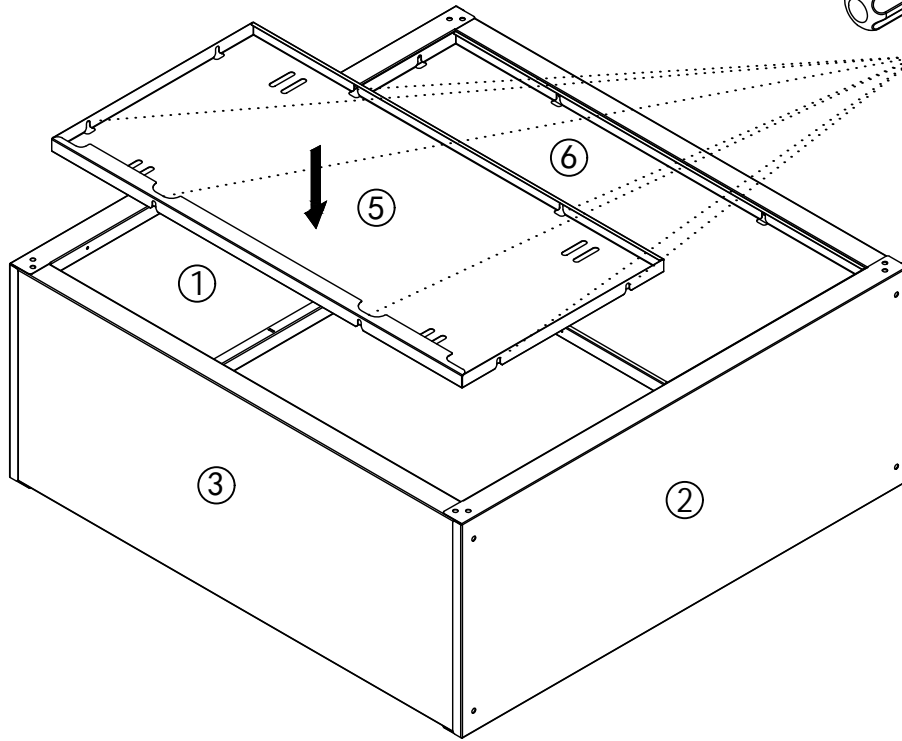

“
Position part ⑤
on the part ③
for mounting the
cabinet.”

STEP 8

- 1- Turn the cupboard so that it will stand in the position of use
- 2- Fix E to part ① and ②, as shown here below

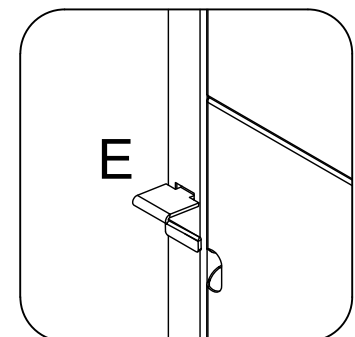
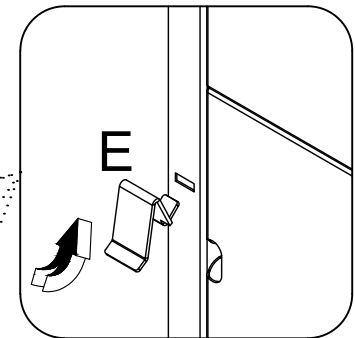
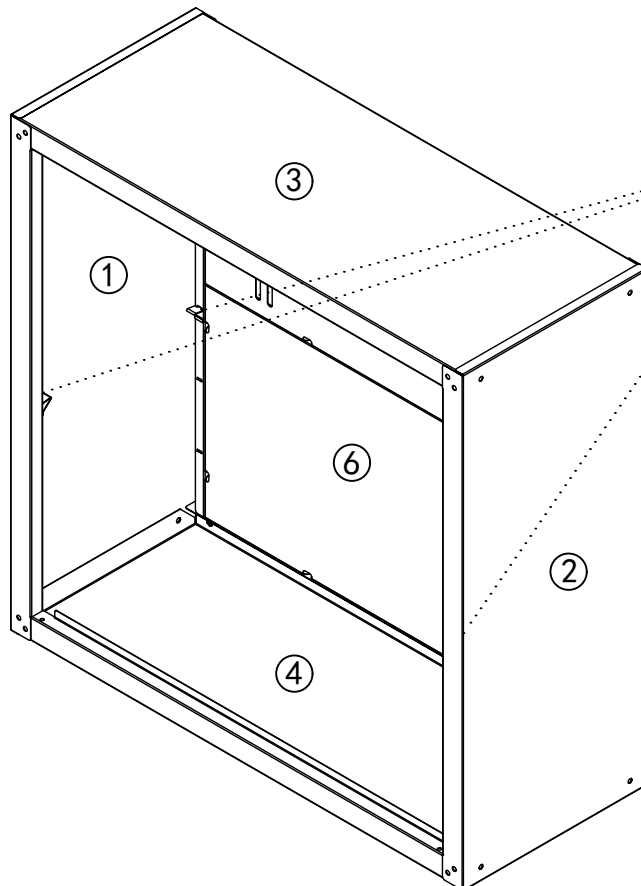

STEP 9

- 1 - Place part ⑦ diagonally so it fits inside the cupboard
- 2 - Lean part ⑦ to part ① & part ② and place it over the E detailed in the illustration here below
- 3 - Bend the other side of part ⑦ down, leaning it over the left E

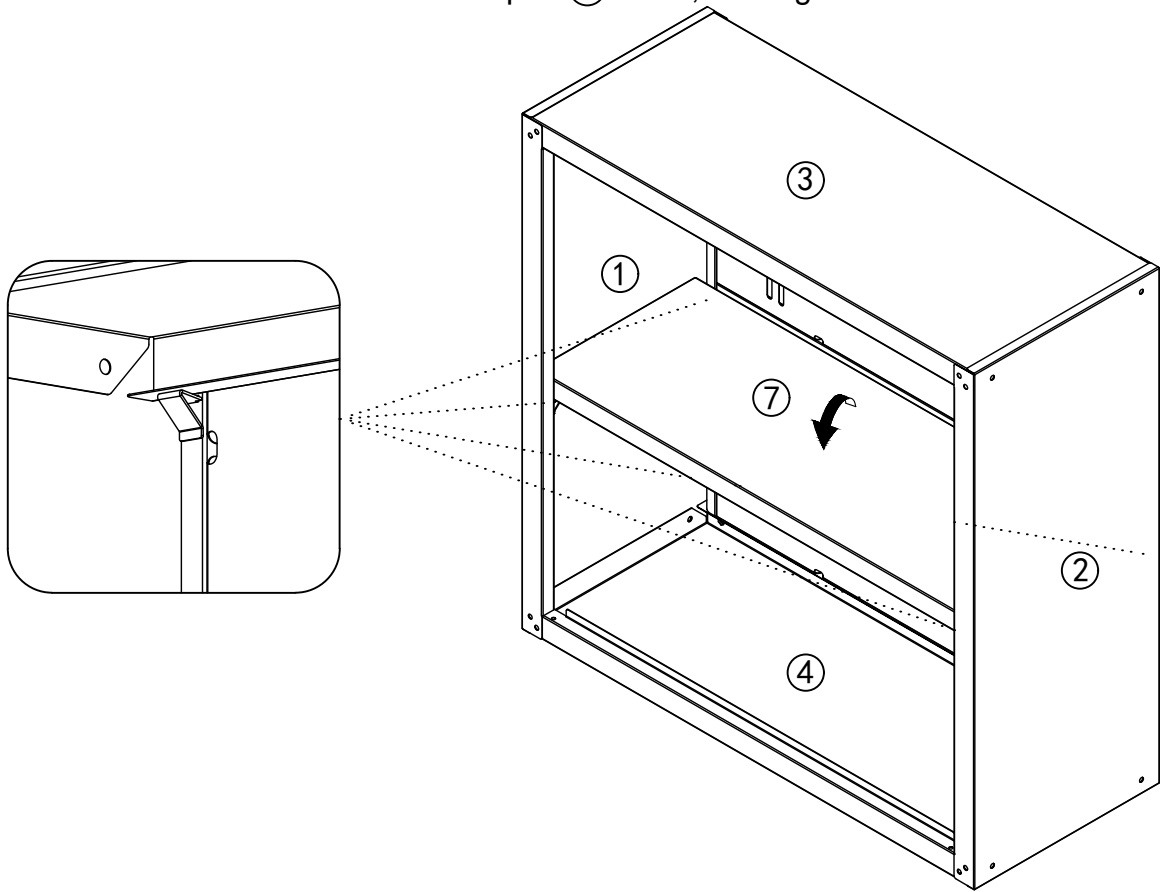

STEP 10

- 1 - Align part ⑩ at an approximate height of 72 1/2" from the floor
- 2 - Align the part using a level
- 3 - Mark the wall using holes of part ⑩, aided by a pencil
- 4 - Drill the wall where marked on the wall, with the pencil using a driller with a 1/3" (8 mm) drill

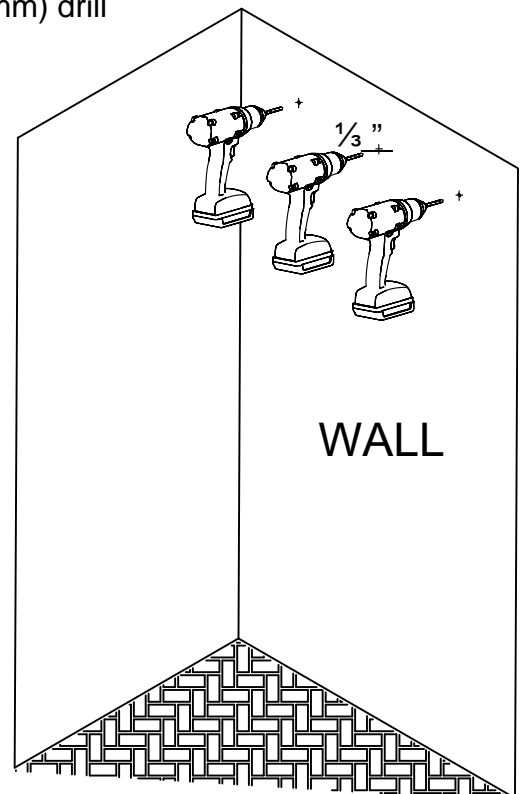
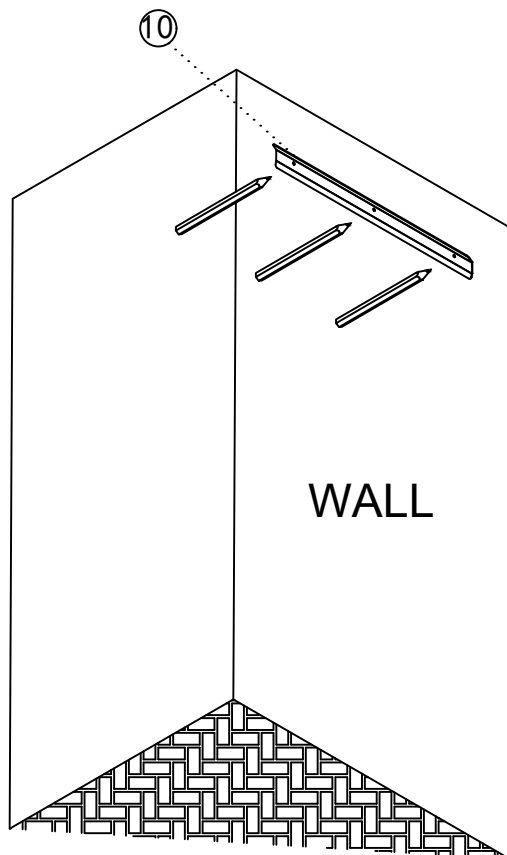

STEP 11

- 1 - Insert the plastic expansion bolt part J into the holes.
- 2 - Use the hammer to insert part J until it overcomes the wall.

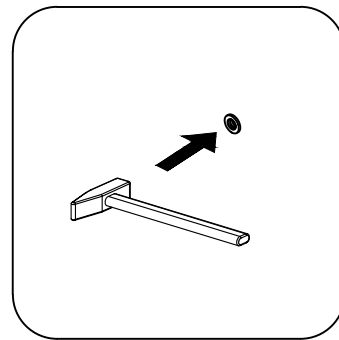
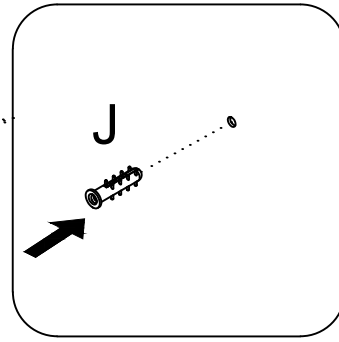
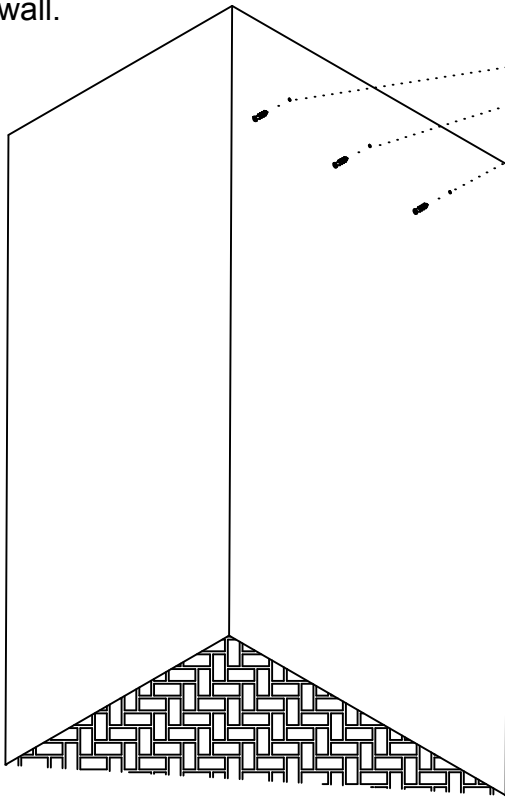
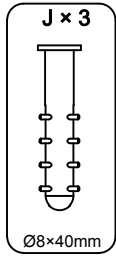

STEP 12

- 1 - Align part ⑩ to the bushings and fix them with H.

- 2 - Fix the cupboard to part ⑩, held to the wall. Part ⑤ tab shall be used to this purpose

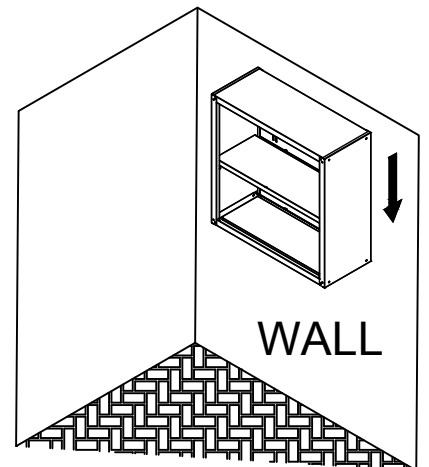
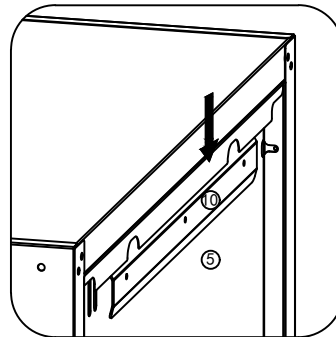
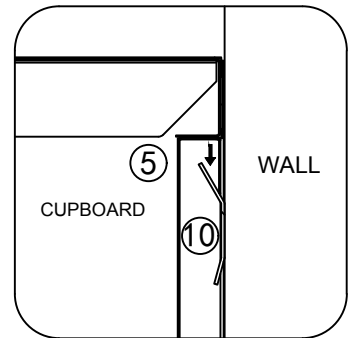
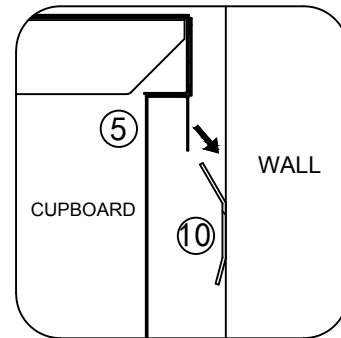
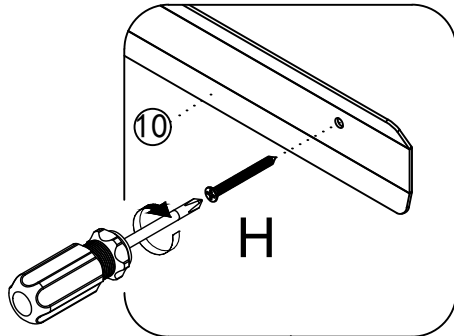
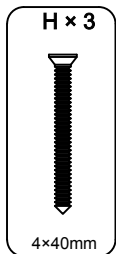

WARNING
The cupboard must be fixed onto the wall

STEP 13

1 - Insert the magnets M in the holes of door ⑧

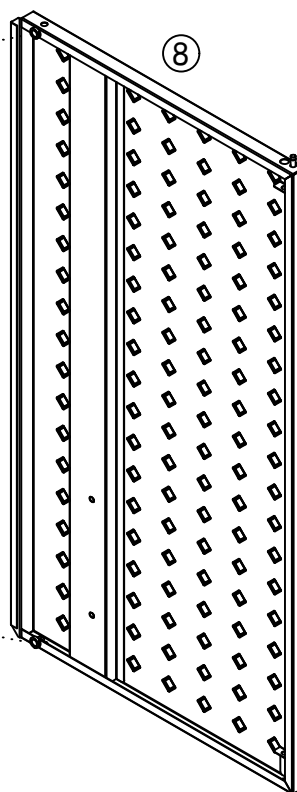
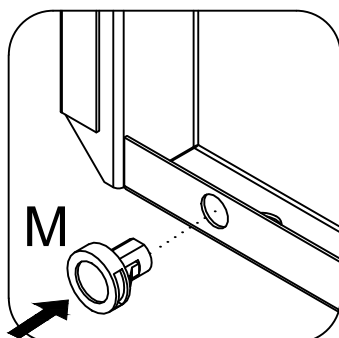
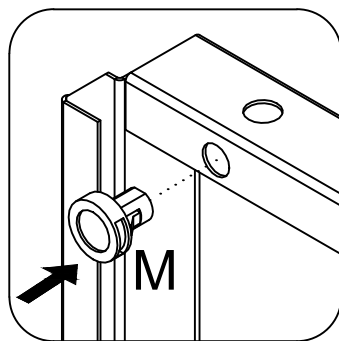

STEP 14

1 - Insert the magnets M in the holes of door ⑨

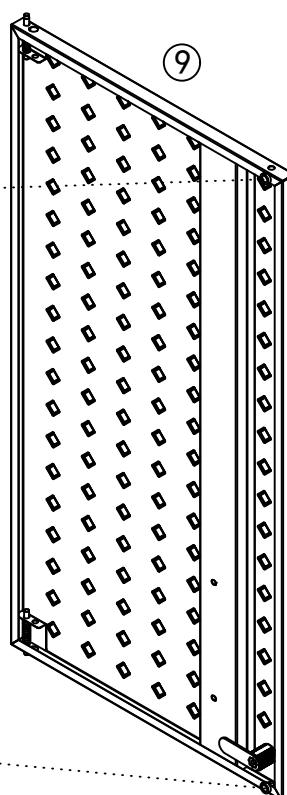
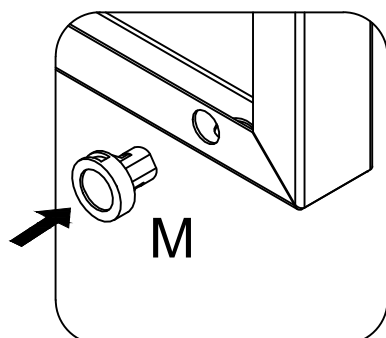
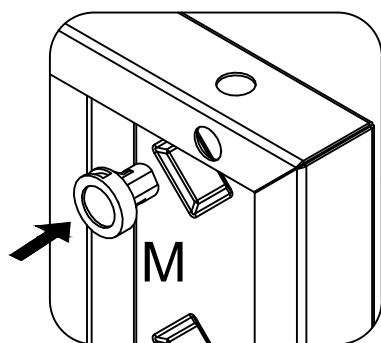
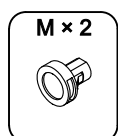

STEP 15

- 1 - To assembly the doors, fit door part ⑧ lower hinge bolt inside the hole in part ④
- 2 - Then, pull the pin of door part ⑧ upper hinge down; align the door and release the pin to fit the hole in part ③
- 3 - Repeat the step for door part ⑨

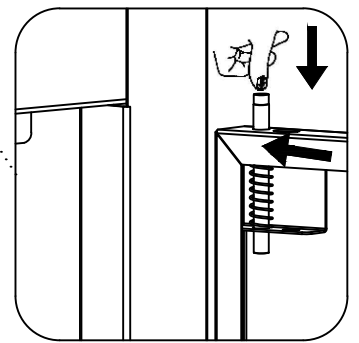
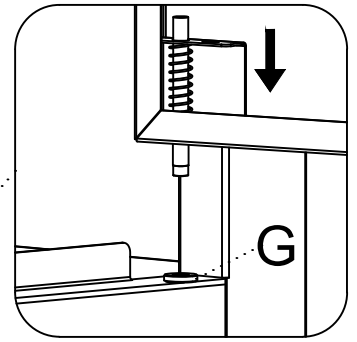
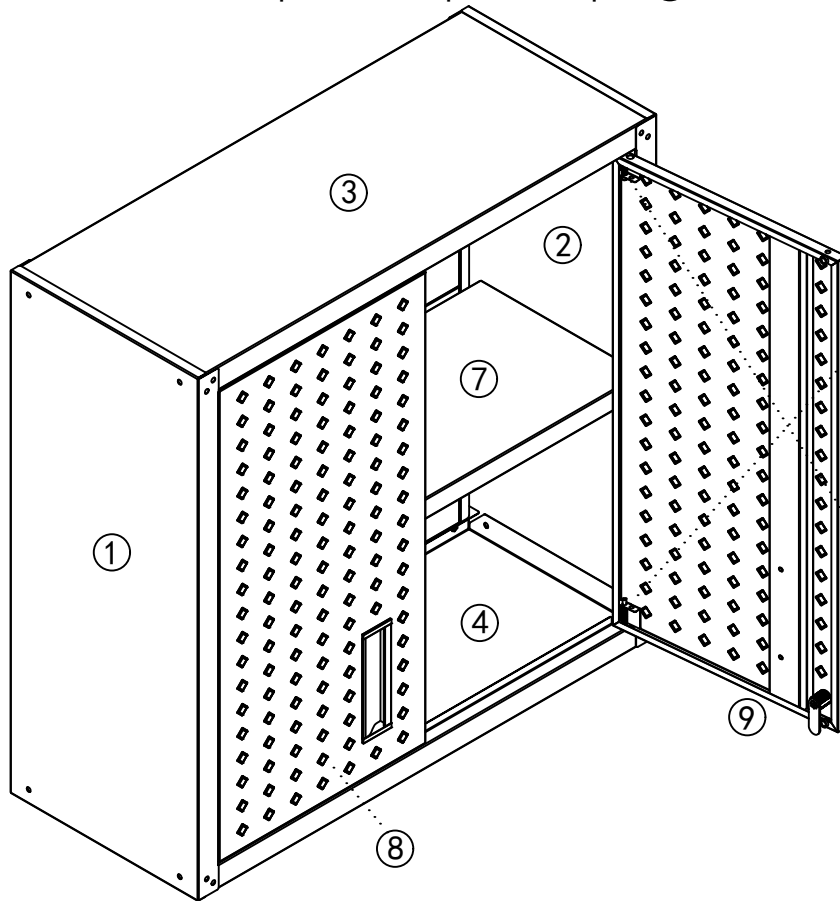
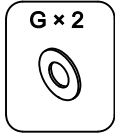

STEP 16

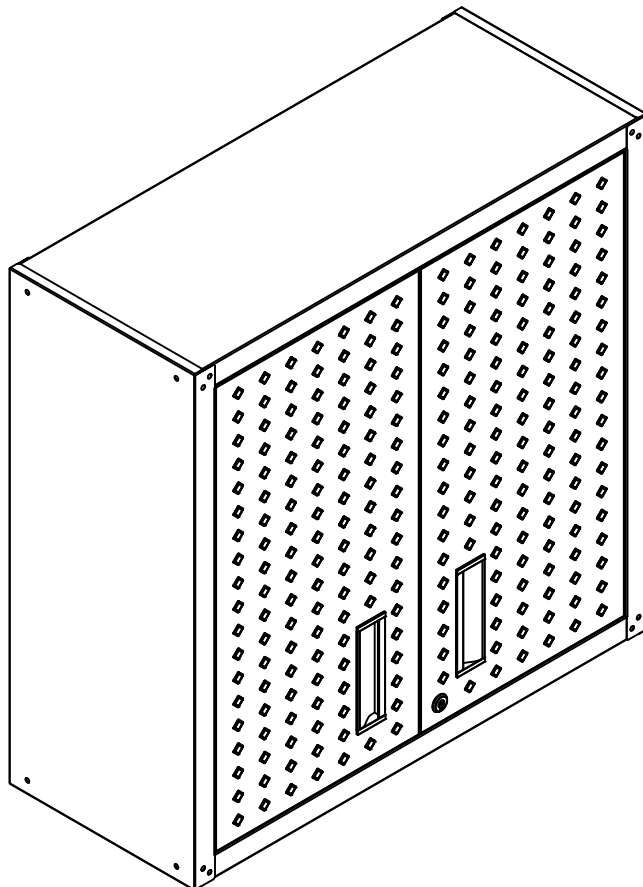



WARRANTY POLICY

All Manhattan Comfort furniture products are warranted, to the original purchaser at the time of purchase and for a period of 30 days thereafter.

Our warranty is limited to new products purchased in factory sealed cartons. This warranty is valid in the United States of America and Canada.

In order to provide you with timely assistance, please thoroughly inspect your furniture for missing or defective parts immediately after opening the carton.

Manhattan Comfort offers a 30-day parts replacement warranty on all items.

Our furniture products are not intended for outdoor use.

THE WARRANTY DOES NOT COVER:

- Defects/damages by improper assembly or disassembly.
- Defects/damages caused by shipping. Claims for damage during transit should be placed immediately to the transportation company.
- Defects/damages caused by inappropriate use of the furniture.



319 Ridge Rd. Dayton, NJ 08810

908-888-0818